

# Rental Power 200 kW



## Description

This Cummins® rental package is a fully integrated mobile power generation system, providing optimum performance, reliability, and versatility for standby and prime power applications.

## Features

### Cummins diesel engines

- U.S. EPA tier III compliant
- Rugged 4-cycle industrial diesel engine with excellent transient performance
- Lightweight, compact and excellent fuel economy
- 2-stage spin on fuel filter w/pre-filter water separator with drain
- Equipped with heavy duty, 2-stage air cleaners with dust ejector

### Control features

- The most advanced, reliable and capable generator set control system on the market today
- Controls provide precise frequency and voltage regulation, alarm and status message display in one easy to operation interface
- Remote monitoring and operation ready
- Auto shutdown at fault detection

### Engine controls

- Oil pressure and water temp gauge
- Fuel level gauge & battery voltage gauge
- Hour meter

### Stamford alternators

- 12-lead reconnectable alternators fitted with voltage selection switch
- Permanent magnet excitation for improved performance in non-linear load applications

### Rental package enclosure

- Sound attenuated, white powder coated lockable enclosure
- Roof mounted, single point lift

- Cooling system rated for 120 °F (50 °C) ambient Complete engine fluid containment reservoir
- Shore power (120 VAC) - No breakers in shore power connection.

### Standard generator electrical features

- Single phase convenience receptacles
- Distribution panel with L1, L2, L3 Neutral and Ground
- Main Line shunt trip type circuit breaker
- Auto start-stop with remote contacts
- Over current sensing
- 3 available auxiliary connections

### Generator electrical options

- Multiple voltage selector switch (480/277 VAC/ 3 phase or 208/120 VAC/3 phase or 240/120 VAC/ 1 phase
- 600/480 V switchable
- Barrel lug connection
- Cam lock distribution panel
- Heated HMI

### Additional rental package features

- Tank style coolant heater
- Low coolant shutdown system
- Battery disconnect switch
- Base mount generator – see Options for trailers

### Rental package options

- DOT approved electric brake trailer with heavy duty center mounted jack, ball or pintle hitch
- DOT approved hydraulic brake trailer with heavy duty center mounted jack, ball or pintle hitch
- 110 V, 5 Amp battery charger
- 20 hour fuel tank (100% prime) with gauge
- Transport Canada UN31A compliant fuel tank

Model	Voltages (V)	Standby rating		Prime rating		Engine model	Alternator model
		60 Hz kW (kVA)	50 Hz kW (kVA)	60 Hz kW (kVA)	50 Hz kW (kVA)		
C200D6R	208/480	200 (250)		180 (225)		QSB7-G5	UCDI274J
	480/600 switchable	200 (250)		180 (225)		QSB7-G5	HCI434C

## Engine specifications

Engine model	QSB7-G5
Alternator data sheet	UCDI274J (208/480), HCI434C (480/600)
Engine data sheet	DS-92278
Tier rating	TPEM (Tier III)
Design	4 cycle, in-line, turbocharged and after-cooled
Bore	107 mm (4.21 in.)
Stroke	124 mm (4.88 in.)
Displacement	6.69 L (408 in <sup>3</sup> )
Cylinder block	Cast iron, in-line 6 cylinder
Battery capacity	2 x 750 cca
Battery charging alternator	100 Amps
Starting voltage	12 volt, negative ground
Fuel system	Direct injection HPCR system
Fuel filter	Spin on fuel filter with water separator
Air cleaner type	2-stage, dry replaceable element with dust ejector
Lube oil filter type(s)	Single spin-on, full flow
Standard cooling system	122 °F (50 °C) ambient radiator

## Alternator specifications

Design	Brushless, 4-pole, drip-proof revolving field
Stator	Double layer concentric, 2/3 winding pitch
Rotor	Single bearing, flexible disc
Insulation system	Class H per NEMA MG1-1.65 (208/480 VAC) Class F per NEMA MG1-1.65 (480/600 VAC switchable)
Standard temperature rise	115/50 °C Prime (208/480 VAC) 95/50 °C Prime (480/600 VAC switchable)
Exciter type	PMG (Permanent Magnet Generator)
Phase rotation	A (U), B (V), C (W)
Alternator cooling	Direct drive centrifugal blower fan
AC waveform total harmonic distortion	< 1.5% no load, < 5% non-distorting balance linear load
Telephone influence factor (TIF)	< 50 per NEMA MG1-22.43
Telephone harmonic factor (THF)	< 2%

## Power capability specifications (Assume power factor = 0.80 for 3 phase Amps)

	Standby rating			
	240 V, 1 phase Amps	208 V, 3 phase Amps	480 V, 3 phase Amps	600 V, 3 phase Amps
C200D6R	542	694*	301	241

\* 240V, 3 phase = 601A

## Electrical power panel specifications

Model voltage	120 V duplex receptacles	240 V twist	Load lug connection (stud diameter)	Load lug circuit breakers
120/480 Volt	2 - 20 Amps GFCI	3 - 50 Amps	1/2 inch	800 Amps
480/600 Volt switchable	0	0	1/2 inch	400 Amps

## Site derating factors

Standby application: The engine may be operated at 1800 rpm up to 3,000 ft (915 m) and 122 °F (50 °C) without power deration. For sustained operation above these conditions, derate by 4% per 1,000 ft (300 m), and 8% per 18 °F (10 °C).

## Control system

### PowerCommand® control

- Integrated automatic voltage regulator and engine speed governor
- Control components designed to withstand the vibration levels typical in generator sets

### Standard control description

- Analog AC frequency meter
- Analog AC voltage meter
- Cycle cranking control
- Digital display panel
- Idle mode control
- Menu switch
- Panel backlighting
- Remote starting, 12 V, 2 wire
- Reset switch
- Run-off-auto switch
- Sealed front panel, gasketed door
- Self-diagnostics

### Standard performance data warnings

- High coolant temperature
- High DC voltage
- Low coolant temperature
- Low DC voltage
- Low oil pressure
- Over current
- Weak battery
- Over speed
- Under frequency
- Intake manifold temperature OOR high/low
- Intake manifold temperature high
- Water in fuel OORH/OORL
- General engine fault
- Coolant level OOR high/low

### Standard protection functions

- Voltmeter/ammeter phase selector
- Warnings
- High coolant temperature
- High DC voltage
- Low coolant temperature
- Low DC voltage
- Low oil pressure
- Over current
- Weak battery

### Shutdowns

- Emergency stop local/remote
- Fail to crank
- High AC voltage
- High coolant temperature
- Low coolant level
- Low AC voltage
- Low oil pressure
- Over current
- Over speed
- Under frequency
- Intake manifold temperature high
- Fail to start/stop
- Over frequency
- Alternator reconnecting switch operated (breaker closed)

### Agency approvals

- NFPA110 for Levels 1 or 2 systems
- ISO 8528-4: 1993 Compliance, Controls and Switchgear
- CE Marking
- EN50081-1, 2 Residential/Light Industrial Emissions or Industrial Emissions
- EN50082-1.2
- ISO 7637-2, Level 2: DC supply surge test
- Mil Std. 202C, Method 101 and ASTM B117: Salt Fog Test
- Designed and manufactured in ISO 9001 certified facilities. Suitable for use on generator sets that are UL 2200 Listed



## Ratings definitions

### Standby:

Applicable for supplying emergency power for the duration of normal power interruption. No sustained overload capability is available for this rating. (Equivalent to Fuel Stop Power in accordance with ISO3046, AS2789, DIN6271 and BS5514). Nominally rated.

### Prime (unlimited running time):

Applicable for supplying power in lieu of commercially purchased power. Prime power is the maximum power available at a variable load for an unlimited number of hours. A 10% overload capability is available for limited time. (Equivalent to Prime Power in accordance with ISO8528 and Overload Power in accordance with ISO3046, AS2789, DIN6271, and BS5514).

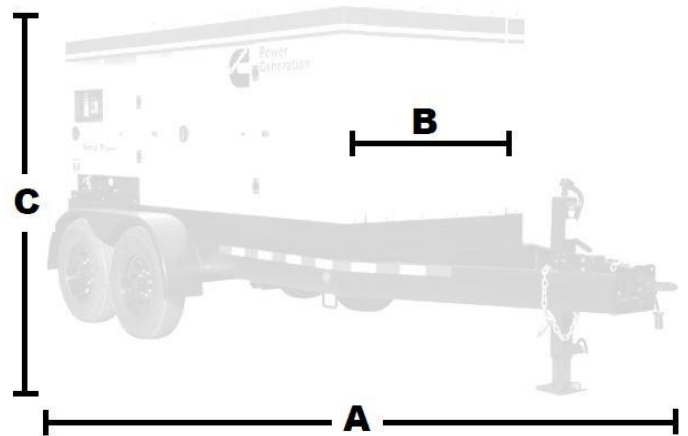

## Dimensions

Model	Dim 'A' mm (in.)	Dim 'B' mm (in.)	Dim 'C' mm (in.)	Weight w/o fuel kg (lbs)	Weight with fuel kg (lbs)	Fuel capacity liters (gal)
C200D6R	3700 (146)	1450 (57)	1700 (67)	2721 (5999)	3542 (7810)	965 (255)
With trailer	5740 (226)	2140 (84)	2309 (84)	3529 (7782)	4351 (9593)	965 (255)

## Fuel consumption

		Standby				Prime			
60 Hz ratings, kW (kVA)		200 (250)				180 (225)			
	Load	¼	½	¾	Full	¼	½	¾	Full
	US Gal/hr	5	9.5	12.9	14.8	4.5	7.8	10.9	13.0
	L/hr	18.9	36	48.8	56	17	29.5	41.3	49.2

## Specifications

Model	kW rating		Sound level at full load dB(A) @ 7 M	Tier rating	Hours of operation (75% load)	
	Standby	Prime			Standby	Prime
C200D6R	200	190	70.5	Tier III	20	23

## Trailer information

Model	Tire size	Tire type	Load range	Number of tires per trailer	Lug pattern
C200D6R	235/85-R16	Radial	2755 lbs - each	4	8 hole

## Certifications

These generator sets are certified to the following standards:



CAN/CSA STD C22.2 NO. 100-04  
CAN/CSA STD C22.2 NO. 14-05

For more information contact your local Cummins distributor or visit [power.cummins.com](http://power.cummins.com)

Our energy working for you.™

888.781.2689  
[www.PrimePowerRentals.com](http://www.PrimePowerRentals.com)